



# GAP90™

Fire Door Head/Jamb Gap Solutions — Up To 90 Minutes

## PRODUCT CUT SHEET

**UL Certified for Head/Jamb Gaps —  
Measuring Over 1/8", and up to 5/16".**



UL CERTIFIED FOR USE IN  
THE US AND CANADA

- POSITIVE PRESSURE – CERTIFIED by UL to ANSI/UL10C, Complies with IBC, NFPA 80 and NFPA 252 for Application to Hollow Metal and Wood Fire Doors Rated up to 90 Minute with Excessive Door and Frame Clearances, Measuring up to 5/16"
- Restricts the Passage of Smoke
- Non-Handed
- Available in 36", 48", 84" and 96" Lengths
- An NGP Strike Shim (9275 or 9225) may also be Required for Proper Latchbolt Engagement
- Doors with Parallel Arm Closers — Use 9990 Fire Door Top Gap Solution.

### GAP90™

Requires Installation of ALL Components:  
9945, 9400, 5075CL

### GAP90DKB™

Requires Installation of ALL Components:  
9945, 9400DKB, 5075B

### 9945

#### Steel Stop Extender

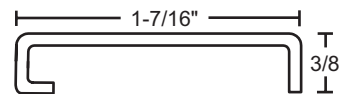

- 16-Gauge, Gray Primer Finish
- Furnished With #10 X 1" TEK SMS
- Patent No.: US9,273,510B2
- Embossed with **UL Mark**

### 5075

#### Self-Adhesive Silicone Seal

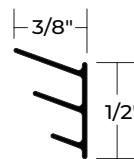

5075B	BROWN
5075CL	CLEAR



### 9400

#### NGP-Edge® Intumescent Seal With PVC Cover

- Self-Adhesive

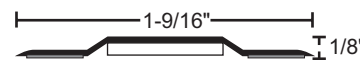

9400	GRAY
9400DKB	BROWN

### INSTALLED VIEW

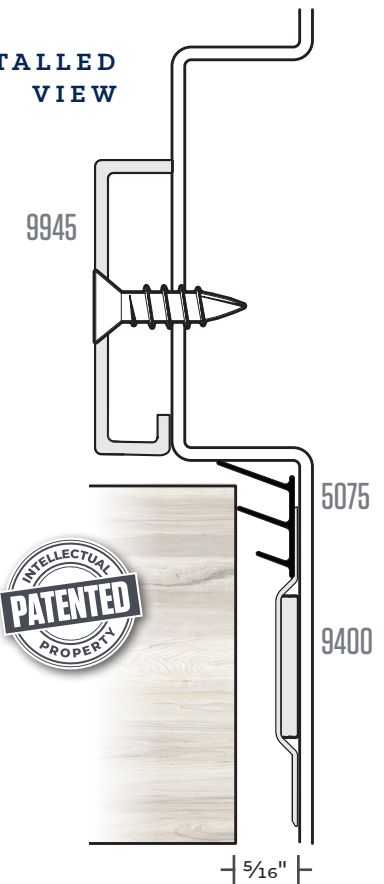

See Adhesive Specifications on Page G15

NGP-GAP-GAP90-PCS-1123-A

## NATIONAL GUARD PRODUCTS, INC.

### MEMPHIS

4985 East Raines Road  
Memphis, TN 38118

### CARSON CITY

3689 Arrowhead Drive  
Carson City, NV 89706

**Fax:** (800) 255-7874

**Email:** info@ngp.com

**Quotes:** quotes@ngp.com

**Orders:** orders@ngp.com

**ngp.com**  
1-800-NGP-RUSH